

HERGOM E-20 SE

Estufa de leña Hergom E-20 SE en hierro fundido con sistema Airwash, potencia de 5,7 kW y eficiencia del 80%. Cumple normativa Ecodesign con mínimas emisiones.



[Ver más información online](#)

FICHA TÉCNICA
DATA SHEET

E-20 SE



hergom

ESTUFAS DE LEÑA
WOOD STOVES

FORJAS
SALVADOR

www.forjas-salvador.com

FORJAS
SALVADOR

www.forjas-salvador.com

E-20 SE

MODELO / MODEL	E-20 SE
Potencia Nominal-Máx. (estimada) / Heat Output Nominal-Max. (estimated)	5,7-10 kW
Rendimiento / Efficiency	80 %
Temperatura de humos / Smoke temperature	253 °C
Emisiones CO (13% O2 Vol%) / CO Emissions (13% O2 Vol%)	0,1 %
CERTIFICADO CE / EC CERTIFICATE	RRF- 40 21 5644
NORMATIVA / NORM	EN 13240
Clasificación energética / Energy efficiency Index	
Dimensiones boca del hogar (AnxAl) Firebox opening dimensions (WxH) (mm)	375 x 245
Longitud máxima de troncos / Maximum log length (mm)	420
Salida de humos / Flue exit	Vertical
Ø Salida de humos / Flue exit Ø (mm)	150
Material hogar / Firebox material	Refractario / Refractory
Doble combustión / Secondary combustion	No
Control aire primario / Air Wash (cristal limpio) Primary Air control / Air Wash	Si / Si Yes / Yes
Control de aire secundario / Secondary air control	Venturi
Toma de aire exterior / Outside air inlet (Ø 80 mm)	No
Peso / Weight (kg)	90

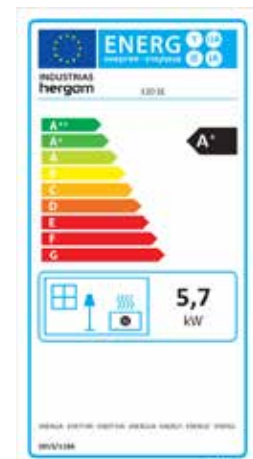

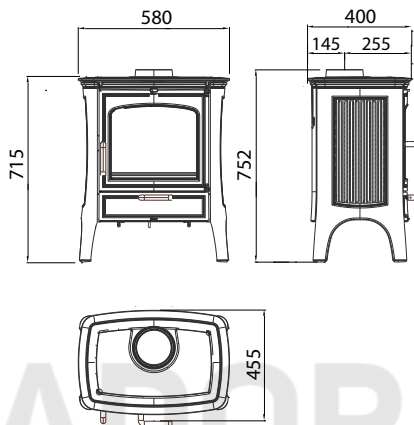

www.forjas-salvador.com



Industrias Hergóm, S.L.
39110 SOTO DE LA MARINA (Cantabria)
Apartado de Correos 208 de Santander
39080 Santander (España)
Tel: +34 942 58 70 00 / Fax: +34 942 58 70 31
comercial@hergom.com

hergom.com

www.forjas-

hergom ⁶⁰ ANIVERSARIO
1959-2019