

## HERGOM CRAFTSBURY HF ESMALTADA MARRON

Estufa Hergom New Craftsbury HF Esmaltada Marrón: diseño vintage en hierro fundido, alta eficiencia energética y cristal limpio. Calor duradero y estilo atemporal.

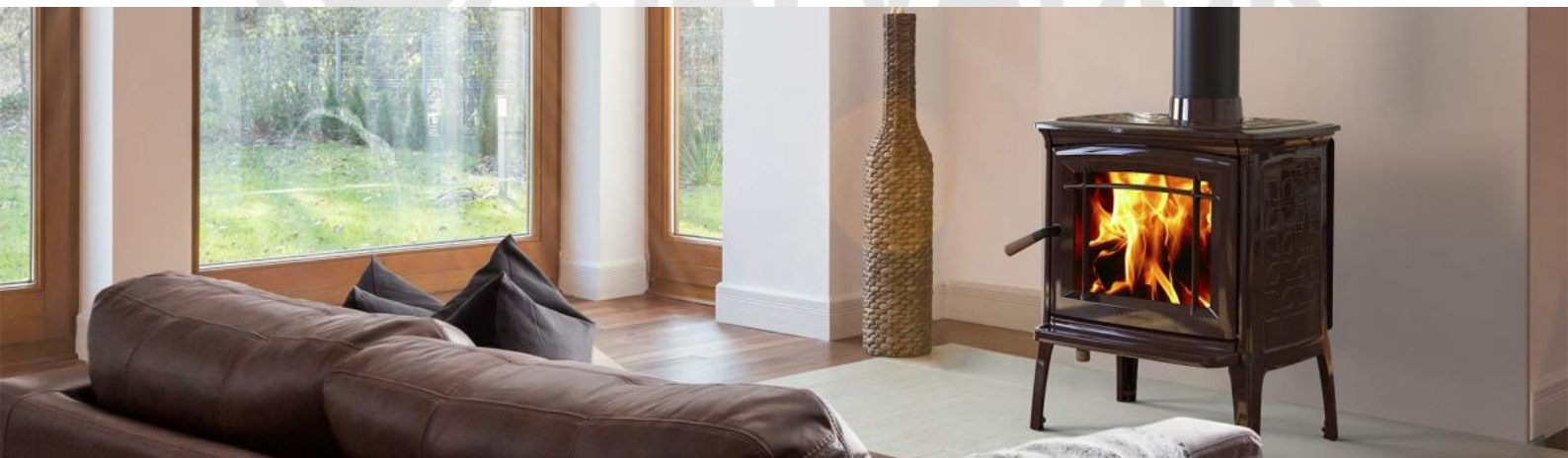

[Ver más información online](#)

FICHA TÉCNICA  
DATA SHEET

# CRAFTSBURY HF



**hergom**

ESTUFAS DE LEÑA  
WOOD STOVES

MODELO / MODEL	CRAFTSBURY HF
Potencia Nominal-Máx. (estimada) / Heat Output Nominal-Max. (estimated)	7-11 kW
Rendimiento / Efficiency	79,1 %
Temperatura de humos / Smoke temperature	288 °C
Emisiones CO (13% O2 Vol%) / CO Emissions (13% O2 Vol%)	0,1 %
CERTIFICADO CE / EC CERTIFICATE	RRF- 40 20 5533
NORMATIVA / NORM	EN 13240
Clasificación energética / Energy efficiency Index	
Dimensiones boca del hogar (AnxAl) Firebox opening dimensions (WxH) (mm)	380 x 285
Longitud máxima de troncos / Maximum log length (mm)	420
Salida de humos / Flue exit	Vertical-Trasera / Top-Rear
Ø Salida de humos / Flue exit Ø (mm)	150
Material hogar / Firebox material	Fundición / Cast iron
Doble combustión / Secondary combustion	No
Control aire primario / Air Wash (cristal limpio) Primary Air control / Air Wash	Si / Si Yes / Yes
Control de aire secundario / Secondary air control	Venturi
Toma de aire exterior / Outside air inlet (Ø 80 mm)	Si / Yes
Peso / Weight (kg)	130

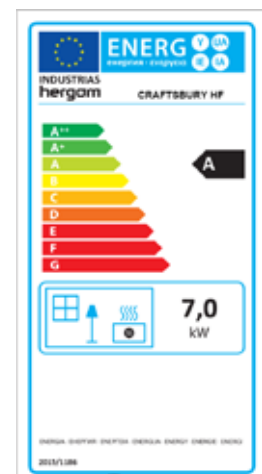



NEGRO MATE  
MATTE BLACK



ESMALTE MARRÓN MAYÓLICA  
MAJOLICA BROWN ENAMEL



FORJAS SALVADOR

\*Acabado interior en HF tratado con fundente blanco para resaltar el efecto de las llamas y ofrecer mayor luminosidad.

Cast iron interior with a white enamel base coat to enhance the flame effect and offer greater luminosity.

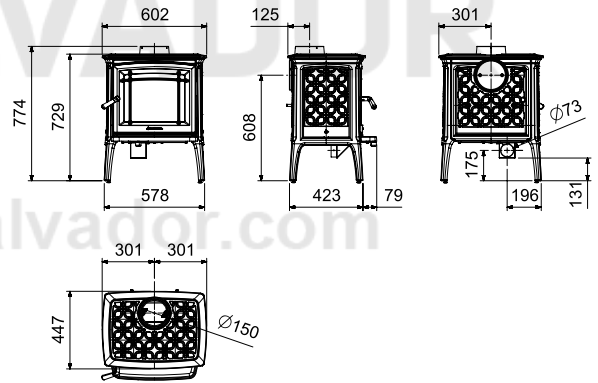

hergam

**Industrias Hergóm, S.L.**  
39110 SOTO DE LA MARINA (Cantabria)  
Apartado de Correos 208 de Santander  
39080 Santander (España)  
Tel: +34 942 58 70 00 / Fax: +34 942 58 70 31  
**comercial@hergom.com**

**hergom.com**

www.forjas-

**hergom** **60** ANI  
VER SARIO  
1959-2019