

FERLUX KALIO

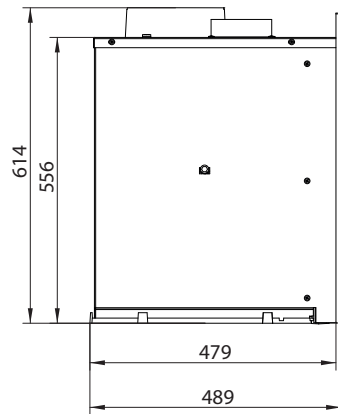

[Ver más información online](#)

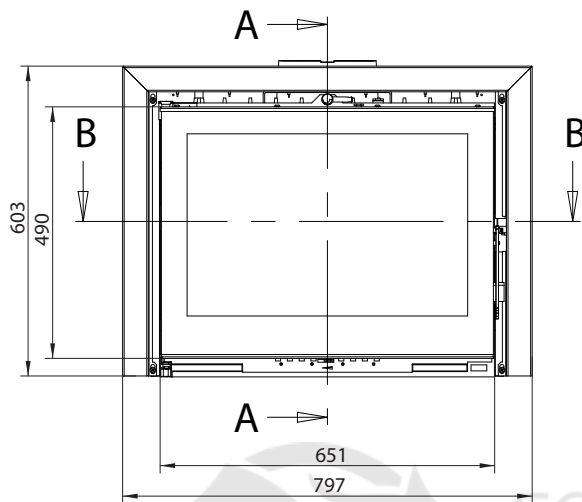

A-A

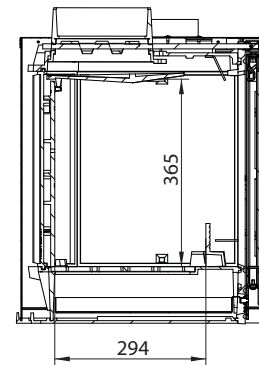

CHIMENEAS Y BARBACOAS FERLUX, S.A.
 POLIG. INDUST. EL POLEAR, PARC. 1
 29313 VILLANUEVA DEL TRABUCO MALAGA (ESPAÑA)
 TEL. +34 952 03 11 17 FAX +34 952 03 11 18

Datos técnicos

POTENCIA TÉRMICA NOMINAL	12,4 Kw
RENDIMIENTO	78,2 %
VOLUMEN CALEFACTABLE	323 M ³
EMISIONES CO (13% DE O ₂)	0,120 %
PARTICULADO (13% DE O ₂)	33,2 MG/NM ³
OGC (13% DE O ₂)	87,2 MG/NM ³
NOX (13% DE O ₂)	184,0 MG/NM ³
TEMPERATURA DE HUMOS	287,0 °C
TIRO MEDIO	10 - 14 PA
CONSUMO	3,53 KG/H
SALIDA DE HUMOS	200 MM
SALIDA DE CANALIZACIÓN	2x120 MM
ENTRADA DE AIRE	N.D.
PESO	141 KG
LONG. MÁX. LEÑA	500 MM
CRISTAL	646x484,5x4 MM

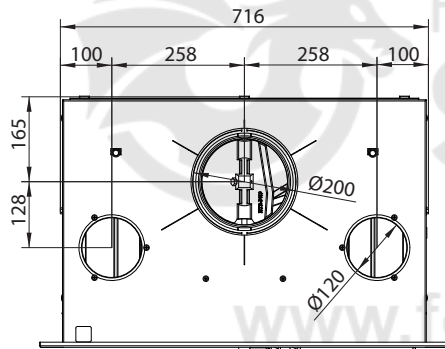

B-B

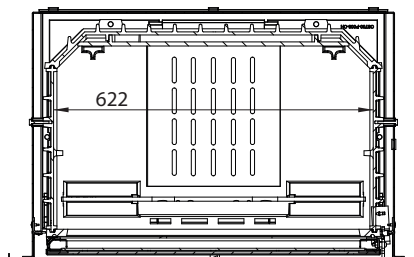

Requisitos eléctricos

ALIMENTACIÓN	220 - 230 V
FRECUENCIA	50 - 60 Hz
POTENCIA MEDIA ABSORBIDA	38 W