

HERGOM C-16/70 N HF

Insertable de leña Hergom C-16/70 N HF con máxima eficiencia con doble combustión, gran potencia, diseño en hierro fundido y distribución de calor óptima y sostenible.



[Ver más información online](#)

FICHA TÉCNICA
DATA SHEET

C-16/70 HF



hergom

INSERTS DE LEÑA
WOOD INSERTS



FORJAS



FORJAS

SALVADOR

MODELO / MODEL	C-16/70 HF
Potencia Nominal-Máx. (estimada) / Heat Output Nominal-Max. (estimated)	8-13 kW
Rendimiento / Efficiency	77 %
Temperatura de humos / Smoke temperature	324 °C
Emisiones CO (13% O2 Vol%) / CO Emissions (13% O2 Vol%)	0,11
CERTIFICADO CE / EC CERTIFICATE	RRF- 29 20 5581
NORMATIVA / NORM	EN 13229
Clasificación energética / Energy efficiency Index	A
Dimensiones boca del hogar (AnxAl) Firebox opening dimensions (WxH) (mm)	534 x 262
Longitud máxima de troncos / Maximum log length (mm)	500
Salida de humos / Flue exit	Vertical
Ø Salida de humos / Flue exit Ø (mm)	150
Ø Salidas de canalización / Convection exits Ø (mm)	2 x 120
Doble combustión / Secondary combustion	Si / Yes
Control aire primario / Air Wash (cristal limpio) Primary Air control / Air Wash	Si / Si Yes / Yes
Control de aire secundario / Secondary air control	Venturi
Toma de aire exterior / Outside air inlet (Ø 80 mm)	Si / Yes
Turbina tangencial 42 W / Convection Blower 42 W	Si / Yes
Nivel sonoro / Sound level	41/45 dBA
Peso / Weight (kg)	120

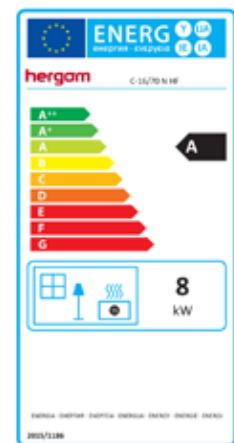

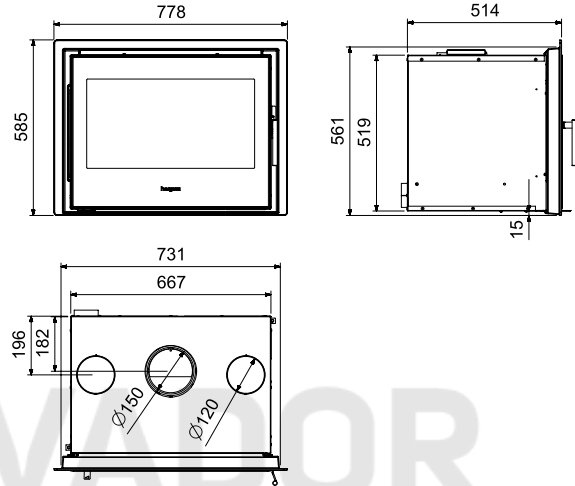

*Acabado de serie con marco de HF 3 caras. De manera opcional se puede suministrar con marco de acero de remate 4 caras.
 Cast iron finishing frame included. A 4 sided steel frame is offered as an option.



Industrias Hergóm, S.L.
39110 SOTO DE LA MARINA (Cantabria)
Apartado de Correos 208 de Santander
39080 Santander (España)
Tel: +34 942 58 70 00 / Fax: +34 942 58 70 31
comercial@hergom.com

hergom.com

www.forjas-

hergom **60** ANI
VER SARIO
1959-2019