

## HERGOM E-30 M FUNDICIÃ<sup>3</sup>N

Descubre la estufa Hergom E-30 M: alta eficiencia, diseño robusto y visión del fuego espectacular. Calor sostenible para tu hogar.



[Ver más información online](#)

FICHA TÉCNICA  
DATA SHEET

# E-30 M



**hergom**

ESTUFAS DE LEÑA  
WOOD STOVES

FORJAS

FORJAS

MODELO / MODEL	E-30 M
Potencia Nominal-Máx. (estimada) / Heat Output Nominal-Max. (estimated)	9-13 kW
Rendimiento / Efficiency	79,2 %
Temperatura de humos / Smoke temperature	281 °C
Emisiones CO (13% O2 Vol%) / CO Emissions (13% O2 Vol%)	0,1 %
CERTIFICADO CE / EC CERTIFICATE	RRF- 40 13 3248
NORMATIVA / NORM	EN 13240
Clasificación energética / Energy efficiency Index	
Dimensiones boca del hogar (AnxAl) Firebox opening dimensions (WxH) (mm)	430 x 310
Longitud máxima de troncos / Maximum log length (mm)	470
Salida de humos / Flue exit	Vertical
Ø Salida de humos / Flue exit Ø (mm)	150
Material hogar / Firebox material	Fundición / Cast iron
Doble combustión / Secondary combustion	No
Control aire primario / Air Wash (cristal limpio) Primary Air control / Air Wash	Si / Si Yes / Yes
Control de aire secundario / Secondary air control	Si / Yes
Toma de aire exterior / Outside air inlet (Ø 80 mm)	Si / Yes
Peso / Weight (kg)	150

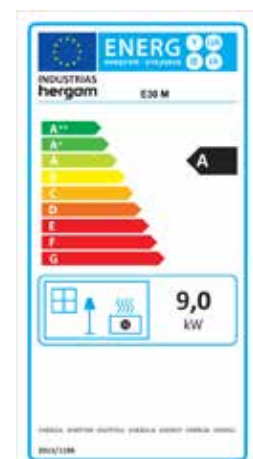

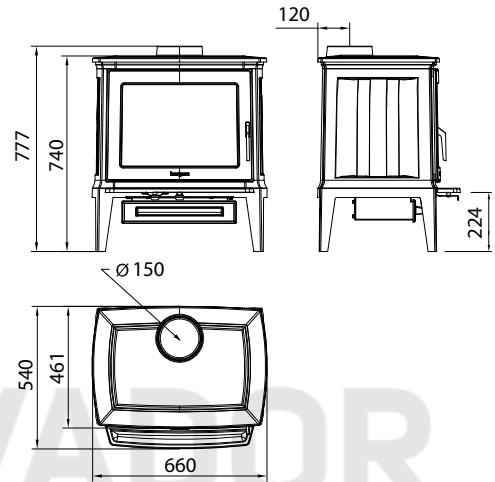

\*Acabado interior en HF tratado con fundente blanco para resaltar el efecto de las llamas y ofrecer mayor luminosidad.

Cast iron interior with a white enamel base coat to enhance the flame effect and offer greater luminosity.

www.forjas-salvador.com



**Industrias Hergóm, S.L.**  
39110 SOTO DE LA MARINA (Cantabria)  
Apartado de Correos 208 de Santander  
39080 Santander (España)  
Tel: +34 942 58 70 00 / Fax: +34 942 58 70 31  
**comercial@hergom.com**

**hergom.com**

www.forjas-

**hergom** **60** ANI  
VER SARIO  
1959-2019