

HERGOM SERE 100 F HF

Insertable Hergom Sere 100 F HF de alta eficiencia, 12 kW de potencia, doble combustión, ventilación ajustable y diseño elegante para calefacción eficaz.



[Ver más información online](#)

FICHA TÉCNICA
DATA SHEET

SERE 100 SE



hergom

INSERTS DE LEÑA
WOOD INSERTS

MODELO / MODEL	SERE 100 SE
Potencia Nominal-Máx. (estimada) / Heat Output Nominal-Max. (estimated)	11-18 kW
Rendimiento / Efficiency	80,4 %
Temperatura de humos / Smoke temperature	179 °C
Emisiones CO (13% O2 Vol%) / CO Emissions (13% O2 Vol%)	0,06
CERTIFICADO CE / EC CERTIFICATE	CPR-B-00442-22
NORMATIVA / NORM	EN 13229
Clasificación energética / Energy efficiency Index	A
Dimensiones boca del hogar (AnxAl) Firebox opening dimensions (WxH) (mm)	820 x 250
Longitud máxima de troncos / Maximum log length (mm)	700
Salida de humos / Flue exit	Vertical
Ø Salida de humos / Flue exit Ø (mm)	200
Ø Salidas de canalización / Convection exits Ø (mm)	2 x 120
Doble combustión / Secondary combustion	Si / Yes
Control aire primario / Air Wash (cristal limpio) Primary Air control / Air Wash	Si / Si Yes / Yes
Control de aire secundario / Secondary air control	Venturi
Toma de aire exterior / Outside air inlet (Ø 80 mm)	Si / Yes
Ventiladores de convección / Convection Blowers	Si / Yes
Material hogar / Firebox material	Vermiculita / Vermiculite
Peso / Weight (kg)	134

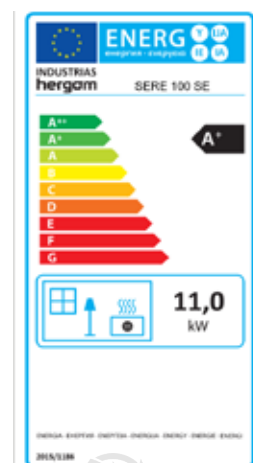

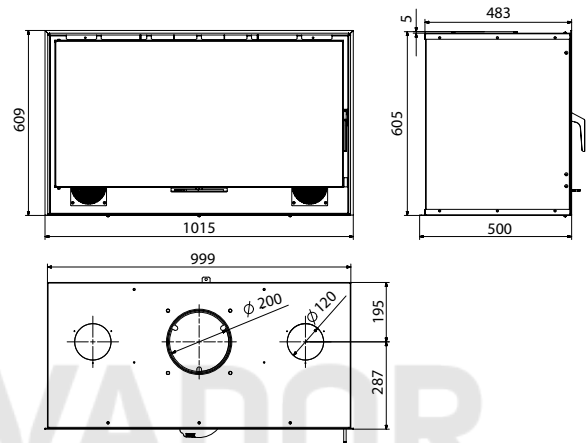

***Los modelos Sere precisan la incorporación de un marco de remate, a elegir entre las 3 opciones disponibles. Sere models require the installation of a finishing frame, to choose from 3 available options.**

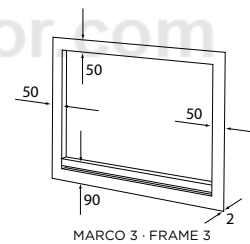
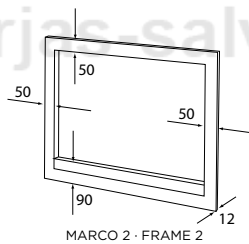
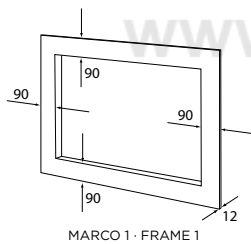

Industrias Hergóm, S.L.
39110 SOTO DE LA MARINA (Cantabria)
Apartado de Correos 208 de Santander
39080 Santander (España)
Tel: +34 942 58 70 00 / Fax: +34 942 58 70 31
comercial@hergom.com

hergom.com

www.forjas-

hergom **60** ANI
VER SARIO
1959-2019